

# MDCSim: A Multi-tier Data Center Simulation Platform

Seung-Hwan Lim, Bikash Sharma, Gunwoo Nam, Eun Kyoung Kim, and Chita R. Das

*Department of Computer Science and Engineering, The Pennsylvania State University  
University Park, PA 16802, USA*

{seulim, bus145, gnam, ekkim, das}@cse.psu.edu

**Abstract**—Performance and power issues are becoming increasingly important in the design of large, cluster-based multi-tier data centers for supporting a multitude of services. The design and analysis of such large/complex distributed systems often suffer from the lack of availability of an adequate physical infrastructure. This paper presents a comprehensive, flexible, and scalable simulation platform for in-depth analysis of multi-tier data centers. Designed as a pluggable three-level architecture, our simulator captures all the important design specifics of the underlying communication paradigm, kernel level scheduling artifacts, and the application level interactions among the tiers of a three-tier data center. The flexibility of the simulator is attributed to its ability in experimenting with different design alternatives in the three layers, and in analyzing both the performance and power consumption with realistic workloads. The scalability of the simulator is demonstrated with analyses of different data center configurations. In addition, we have designed a prototype three-tier data center on an Infiniband Architecture (IBA) connected Linux cluster to validate the simulator. Using RUBiS benchmark workload, it is shown that the simulator is quite accurate in estimating the throughput, response time, and power consumption. We then demonstrate the applicability of the simulator in conducting three different types of studies. First, we conduct a comparative analysis of the IBA and 10 Gigabit Ethernet (10GigE) under different traffic conditions and with varying size clusters for understanding their relative merits in designing cluster-based servers. Second, measurement and characterization of power consumption across the servers of a three-tier data center is done. Third, we perform a configuration analysis of the Web server (WS), Application Server (AS), and Database Server (DB) for performance optimization. We believe that such a comprehensive simulation infrastructure is critical for providing guidelines in designing efficient and cost-effective multi-tier data centers.

## I. INTRODUCTION

Design of high performance, power-efficient, and dependable cluster based data centers has become an important issue, more so with the increasing use of data centers in almost every sector of our society: academic institutions, government agencies and a myriad of business enterprises. Commercial companies such as Google, Amazon, Akamai, AOL, and Microsoft use thousands of servers in a data center environment to handle high volume of traffic for providing customized (24x7) service. A recent report shows that financial firms spend around 1.8 billion dollars annually on data centers for their businesses [1]. However, it has been observed that

data centers contribute to a considerable portion of the overall delay for web-based services and this delay is likely to increase with more dynamic web contents. Poor response time has significant financial implications for many commercial applications. The power consumption of data centers is also drawing much attention, leading to the concept of "Green Data Centers". As reported in [2], data centers in the U.S. consumed 61 billion kilowatt-hour of electricity in 2006 at the cost of \$4.5 billion. It is estimated that data centers' power consumption will increase by 4% to 8% annually and is expected to reach 100 billion kWh by 2011. Thus, future data center's design must focus on three critical parameters: high performance, power/thermal-efficiency and reliability.

Measurement, modeling, and simulation are common approaches for the analysis of a system. Measurement is a credible approach for analyzing the system, but the associated cost and time is high. Modeling offers a simple representation of the construction and working of the system of interest. However, developing a model with high accuracy and flexibility is not always feasible. Simulation fills in the above deficiencies by providing a flexible and operative working model of a system. A simulator can well outline a more detailed view of a system than modeling. It is also an economical and less time-consuming option as compared to the real implementation of a system.

Analysis of multi-tier data centers has been done using measurement and modeling in [3], [4], [5]. However, the scale and scope of analysis is restricted to small size clusters or to an individual tier. In most of the studies on data centers, the size of the system analyzed is limited because of practical difficulties encountered in testing large scale systems [3], [4]. There is a growing need to analyze data centers on a large scale. In addition, despite the growing popularity of multi-tier data centers, to the best of our knowledge, simulating a multi-tier data center including the functionalities of all the tiers together has not been attempted. Keeping in view the importance of growing data centers and the above limitations in the analysis of them, we propose a simulation platform for the design and analysis of large scale, multi-tier data centers.

Our simulation platform is comprehensive, flexible, and scalable. The comprehensiveness comes from the fact that important salient features of a multi-tier data center are implemented in detail. It is flexible as we can manipulate different features of the data center. For example, the number of tiers

can be changed, the scheduling algorithms can be customized, the type of interconnection used can be altered and so also the communication mechanisms. Further, the layered architecture allows for the modification of individual layers without affecting the other layers. Simulation experiments are possible with large number of nodes across the cluster, making it scalable and apt to existing data centers' trends.

For the validation of our simulator, we first designed and implemented a prototype three-tier data center on an IBA and 10GigE connected Linux cluster. The major components of this prototype includes a web server (WS) tier, an application server (AS) tier, and a database server (DB) tier. The web traffic was generated by RUBiS [6] workload, which gets distributed using a simple round-robin web switch. Since the prototype was limited in terms of the number of cluster nodes, system configurations, and driving workloads, we designed the proposed simulation framework to overcome these limitations. The simulator was validated with RUBiS benchmark measurements on the above mentioned prototype data center. The average deviation of simulation results from real measurements was found to be around 10% for the latency and 3% for the power consumption.

Using our simulator, we experimented with three important applications. First, we performed a comparative analysis of IBA and 10GigE under different cluster configurations and with varying load. Next, we conducted power measurement in multi-tier data center. Finally, we presented a methodology for the determination of optimal cluster configurations in terms of performance (latency) through simulation experiments. Our experimental results for the comparative analysis between 10GigE and IBA show that IBA outperforms 10GigE both with and without TCP Offload-Engine (TOE) with high traffic, though 10GigE performs better than IBA under low traffic. From the power consumption comparison among IBA, 10GigE with/without TOE connected data centers with various cluster configurations and with varying number of clients, we observed that the power consumption increases with the increase in the traffic across the cluster. Also, the power usage was found to be varying for different cluster configurations even for the same total number of nodes. Finally, simulations with several cluster configurations confirmed the fact that increasing the number of nodes in a multi-tier data center does not always guarantee better performance. There are specific configurations (optimal distribution of nodes across each tier) that can achieve the desired level of performance.

The rest of the paper is organized as follows. In Section II, we discuss the related works. The design of the simulation platform is described in Section III. Prototype design, system configuration and validation of simulator are discussed in Section IV. Our results and discussions are presented in Section V, followed by the concluding remarks and future directions in Section VI.

## II. RELATED WORK

A few researchers have addressed the modeling of a multi-tier data center. Modeling or simulation of each individual

tier separately in a multi-tier data center has been studied in [7], [8], [9], [10]. Modeling of a multi-tier data center has been done in [5], [11]. [5] models a multi-tier data center as a network of queues and [11] models each service tier as a fine-grained component to capture practical implementations of each server. However, the design of a simulation platform for the analysis of multi-tier data centers taking into account the effects of all tiers together has not yet been addressed.

[12] demonstrates the benefits of IBA in multi-tiered web services. But, the system analyzed in [12] is restricted in size and system capability in the sense that it does not include the Java 2 Enterprise Edition (J2EE) [13] based application servers, which have become the *de facto* standard for designing data centers. Our prototype data center includes J2EE specifications. Further, they conducted the comparative analysis with low traffic and small cluster sizes. In this paper, as part of an application of our simulator, we perform the evaluations and comparisons of IBA and 10GigE with/without TOE on a much larger scale and under high load conditions.

Modeling of power consumption in computer systems has been done at various granularity levels, starting from large data center to individual components of a system either through real measurements, estimations from performance counters or using a combination of both [14], [15]. Power management for communication protocols has been studied in [3], [16], [17]. [3] compared the power based benefits of using Remote direct memory access (RDMA) adapters, such as IBA and 10 GigE with TOE against TCP/IP Ethernet. However, they conducted their experiments by using only two servers and with micro-benchmarks. Moreover, energy consumption in server farms using simulation is studied in [17], though the scale of simulation is restricted (results for only up to 32 nodes are shown). Our simulation results for power measurement across the servers of a data center span over cluster configuration with much larger nodes. Besides, there have been significant researches on power management methodologies that focus only on individual tiers such as a web server tier without taking into consideration the effects of all the tiers of a multi-tier data center. For example, [18], [19] analyze only front end power and energy management techniques. [20] discusses local and cluster-wide power management techniques using just a web server simulator. The simulator proposed in this work considers the effects of all tiers and can accurately estimate power consumption across the servers of a multi-tier data center.

To the best of our knowledge, no previous works have looked at multi-tier data center simulator, which can analyze a cluster based data center with detailed implementation of each individual tier. Also, power measurement in a large consolidated environment like a multi-tier data center has not been analyzed using a comprehensive multi-tier simulator in previous literatures.

## III. DESIGN OF SIMULATION PLATFORM

In this section, we discuss the design and implementation issues of our simulation platform. The functional building

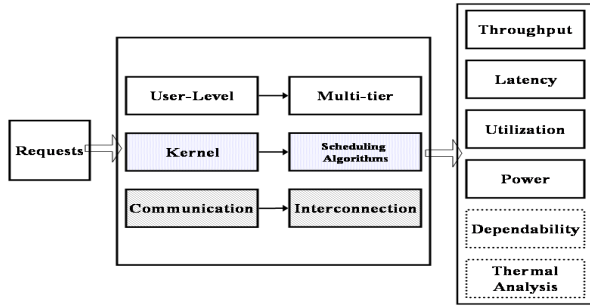

Fig. 1. Functional Overview of Simulation Platform

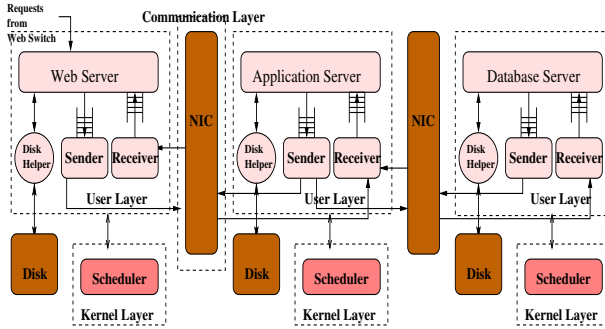

Fig. 2. Architectural Details of the Three Layers of Simulation Platform

blocks of our multi-tier data center simulator, written in CSIM [21], are shown in Figure 1.

The simulation is configured into three layers (a communication layer, a kernel layer and a user-level layer) for modeling the entire stack starting from the communication protocols to the application specifics. Such a three layer abstraction provides the flexibility and scalability in analyzing various design details as described next. Intra-cluster communication is modeled at the communication layer. For intra-cluster communication, the simulator supports IBA and Ethernet over TCP/IP as the underlying interconnect technology. The IBA communication modules follow the semantics of the IBA specification [22] and support major functionalities of the IBA, including communication with Completion Queue (CQ) and Send/Receive Queues. Other communication paradigms/protocols can be incorporated into the communication layer by simply plugging in the appropriate timing parameters.

At the kernel layer, we modeled the Linux scheduler 2.6.9, which maintains a run queue for each CPU in the system. Since we assumed all the CPUs in a node as one single resource, we have just one run queue for each server node. Each time the scheduler runs, it finds the highest priority task among communication and application processes in the simulator. If there are multiple tasks with the same priority, those tasks will be scheduled by the round-robin scheme. When calculating the time slice, the scheduler punishes CPU intensive tasks and rewards I/O intensive tasks as Linux 2.6.x kernel does.

The high level application/user layer captures the important characteristics of a three-tier architecture. The user level layer consists of the following categories of processes - WS,

AS, and DB processes; auxiliary processes like disk helper for supplementing server processes; communication processes such as Sender/Receiver processes. The front-end tier (web server tier) is the closest to the edge of a data center and is responsible for serving either static requests from memory or disk or forwarding dynamic requests to application server nodes. In our case, we use Apache [23] as the front end web server interface. The middle tier (application server tier) is responsible for handling the dynamic web contents, and we use the publicly available JOnAS [24]. On receiving the dynamic requests, the application server nodes process them. Being in middle between the front-end and back-end in a data center, application servers include interfaces to both tiers: translating clients' messages in HTML to SQL and vice versa. The AS nodes' functionalities are based on J2EE specifications. To model EJB session beans [9] in our simulator, we implemented the main components - web container which takes care of the presentation logic, EJB container that handles business logic and controls interaction with the database. Finally, the database server, based on the SQL semantics [25], is dedicated for database transactions. It either primarily accesses the cached data in the database or sends a request to disks.

From measurements on our prototype data center (discussed later) with the RUBiS workloads, we observe that 97% of the database requests are satisfied from the cache, thus, only 3% of the requests are directed to the disks. We use these cache and disk access rates in simulating the database tier. Since we assumed mirroring as data sharing method among all the database servers, we modeled locking operation to ensure data coherence. We also assumed that there is one server process per node to simplify the implementation of each tier of our three-tier data center simulator.

The architecture of our simulator is shown in Figure 2. Here, Network Interface Card (NIC) and Disk are devices and others are processes that reside inside the CPU in a server node. We assumed that CPU, Disk, and NIC are basic computing resources in a node responsible to process requests. For simplicity, each resource is modeled as an M/M/1 queue in the simulator. In the simulator, nodes separately process the requests which they receive through the communication layer. After processing the requests, they send the responses back through the communication layer and this procedure follows for every node in the cluster. In addition, since this is an event-driven simulator, we can trace each individual request. Since we simulate each node independently, we can change the configuration of each tier easily, such as varying the total number of nodes in the entire cluster and the number of nodes for each tier.

The main advantages of our simulation platform is that it is comprehensive, flexible, and scalable. It is comprehensive as the critical behavior of an entire data center as well that of each node has been implemented in a lucid manner. For example, we implemented database synchronization and load distribution for web requests in the application layer. The task scheduler was deployed in the kernel layer and the communication primitives are captured in the low level

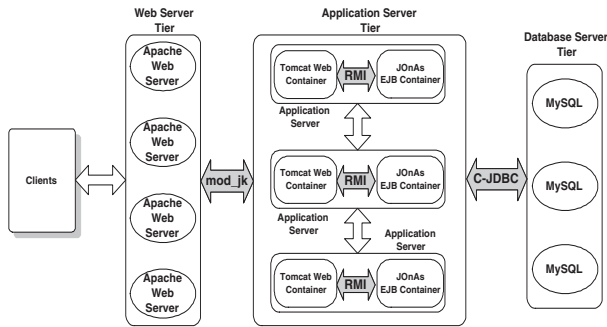

Fig. 3. A Prototype Data Center

communication layer. Its flexibility comes from the fact that the simulator provides the ease to modify the behavior of any entity in a simulator without affecting other parts by simply plugging different parameters, policies, or even implementing different features. For instance, we need to only vary the latency timing parameters to analyze the behavior of both IBA and 10GigE network adapters without changing any other parts of the simulator. Also, we can analyze the behavior of several cluster configurations for optimizing various objective functions without having to rearrange or change our simulator. Moreover, although the current version of the simulator is used for performance and power analysis, it can be extended to study other aspects such as thermal behavior and reliability issues. The scalable aspect of the simulator enables it to simulate large data centers. There can be many possible applications of the simulator such as comparative performance analysis of high speed interconnects, power and thermal analysis, determination of optimal cluster configuration to meet a target performance level, fault tolerance and reliability of data centers.

#### IV. PROTOTYPE CONFIGURATION AND VALIDATION

In this section, we present the design and implementation of a prototype data center, the system configuration, and the simulator validation. As stated in the introduction, we designed a prototype three-tier data center to validate our simulator.

##### A. A Prototype Design

A three-tier data center prototype was designed and implemented as shown in Figure 3 for conducting actual measurements. The major components of this prototype include clients, WS tier, AS tier and DB tier. A simple round-robin web switch emulation was implemented to distribute client requests to the web server tier nodes. The web server nodes, in which Apache 2.0.54 [23] is installed, communicate with the application server nodes through the mod\_jk connector module v.1.2.5. The maximum number of Apache processes was set to 512 to maximize the performance of WS tier, which was found by trial and error. There are many application servers based on J2EE specifications which define the architecture and interfaces for developing Internet server applications for a multi-tier data center. Among them, JOnAS 4.6.6 [24], an open

source application server, is installed in our prototype data center. TomcatWeb container 5.0.30 is integrated with JOnAS as the web container. Remote Method Invocations (RMI) provide intra-cluster communication among the AS tier servers. Sun's JVM from JDK 1.5.0\_04 for Linux was used to run JOnAS. EJB session beans version were employed to achieve the best performance as reported in [9]. Communication between AS-tier and DB tier was achieved through C-JDBC v.2.0.1 [26], which allows EJB container to access a cluster of databases. For the back-end tier, we used multiple machines running MySQL 5.0.15-0 Max [25].

Our prototype is implemented on varying number of dedicated nodes of a 96-node Linux kernel 2.6.9 cluster. Each of these nodes has dual 64-bit AMD Opteron processors, 4 GBytes of system memory, Ultra320 SCSI disk drives and a Topspin host adapter which is InfiniBand v.1.1 compatible. The adapters are plugged into PCI-X 133Mhz slots. Each node has 1Gig-Ethernet adapter of Tigon 3 connected to 64 bit, PCI-X 66Mhz slots. The default communication between all the server nodes is through 1GigE connection. In order to make IBA as our connection backbone instead of Ethernet, we ran all of the server applications with the SDP library (provided by Topspin) in our experiment. We used RUBiS [6] benchmark workload to collect actual measurement data for conducting our experiments since it was difficult to get real workloads because of the proprietary nature of Internet applications.

TABLE I  
TIMING PARAMETERS

Parameter from Measurement	Value (ms)
Context switch	0.050
Interrupt overhead	0.01
TCP connection	0.0815
Process creation overhead	0.352
Disk read time	$7.89 \times 2 + (0.0168 \times \text{Size}) + (\text{Size}/368 - 1) \times 7.89$
Network latency (IBA)	$0.003 + 0.000027 \times \text{Size}$
Network latency (1GigE)	$0.027036 + 0.012 \times \text{Size}$
Parameter from Estimation	Value (ms, KB)
Network latency (TOE)	$0.0005409 + 0.0010891 \times \text{Size}$
Network latency (10GigE)	$0.0009898 + 0.0017586 \times \text{Size}$

TABLE II  
TRAFFIC CHARACTERISTICS

Parameter	Value	
File Size	WS $\rightarrow$ AS	$\alpha = 0.1602, \mu = 5.5974$
	AS $\rightarrow$ DB	$\alpha = 0.4034, \mu = 4.7053$
	DB $\rightarrow$ AS	$\alpha = 0.5126, \mu = 22.134$
	AS $\rightarrow$ WS	$\alpha = 0.5436, \mu = 56.438$
	WS $\rightarrow$ client	$\alpha = 0.5458, \mu = 50.6502$
Dynamic Req/Total Req	0.672	
Avg. DB Req per Dynamic Req	2.36	
Think time interval	Exponential with a mean of 7s	

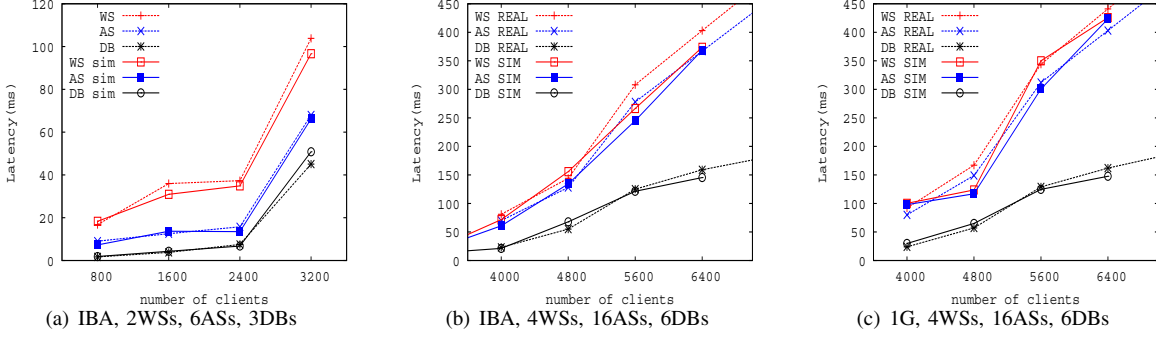

Fig. 4. Latency comparison between measurement and simulation

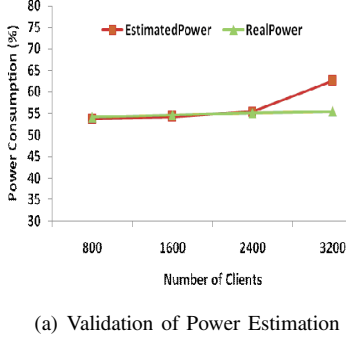

Fig. 5. Power comparison between measurement and simulation

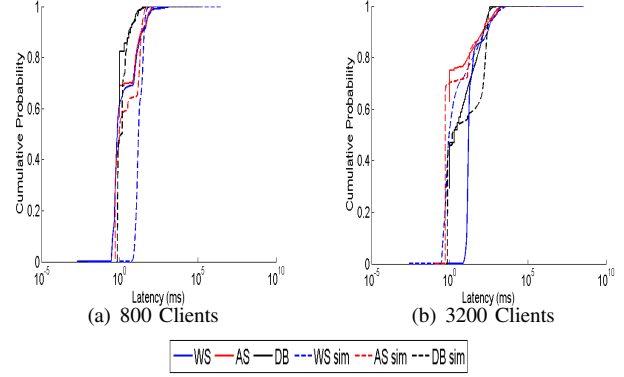

Fig. 6. Service time CDFs from Measurement and Simulation

## B. System Configuration and Workload

Table I summarizes the system and network parameter values used in our experiments. These values were obtained from measurements on our prototype data center using micro benchmarks, hardware specifications, and estimation. System parameters, for example, context switch and interrupt overhead are obtained by running benchmarks. Disk read time is based on the hardware specifications. Network latency and CPU utilization is obtained by estimation, which will be presented in this section. Clients generate requests according to the RUBiS benchmark, which follows the TPC-W compatible specification [27]. For generating the traffic, we assumed the log-normal distribution for the file size as reported in [28] along with the parameters and think time interval of clients shown in Table II.

In order to correctly simulate the characteristics of the AS and DB tier with dynamic requests, estimating CPU service times for AS and DB servers is essential. We estimate the CPU service time of each tier node. From measurements on the prototype, CPU utilization and throughput of each node is obtained. We then use the Utilization Law [5] to obtain the service time as shown in equation (1).

$$T = \frac{\rho}{\tau} \quad (1)$$

where,  $T$  is the service time,  $\rho$  is the utilization of the busiest resource (CPU) and  $\tau$  is the throughput of each node.

Next for simulating 10GigE network adapter, we need the

latency timing equation. Through linear regression analysis, we estimated the latency equations for two kinds of 10GigE implementations (with/without TOE) in terms of message size by obtaining latency from throughput [4] as follows:

$$Latency = \frac{Data\ Size}{Throughput} \quad (2)$$

As reported in [29], the hardware characteristics of 10GigE is almost the same as 1GigE. Further, the network latency for both 1GigE and 10GigE includes similar hardware overheads caused by switches and network interface card. Thus, we can safely assume that our simulator can be extended to capture the behavior of 10GigE.

Our simulator is capable of measuring power consumption across the servers of a multi-tier data center. To incorporate power measurements in our simulator, we measured the server utilization using some modifications to the heuristics given in [18]. The server utilization was measured as

$$U_{server} = \frac{N_{static}A_{static} + N_{dynamic}A_{dynamic}}{Monitor\ Period \times \# \text{ WS nodes}}, \quad (3)$$

where  $N_{static}$  and  $N_{dynamic}$  are the number of static and dynamic requests respectively;  $A_{static}$  and  $A_{dynamic}$  are the average execution time of static and dynamic requests respectively; Monitor Period is the time interval over which we measure server utilization and power. We divided the numerator of the equation for server utilization from [18] by the total number of web server nodes in the cluster, since



our simulator processes the client requests in parallel at the front end tier [30]. We then computed the server utilization using the above equation. Power consumption is expressed as percentage of the peak power across the data center. We used the power model of Wang *et al.* [31] to estimate power consumption. According to their power model, for a fixed operating frequency, both the power consumption of the server and the application throughput are approximately linear functions of the server utilization. The peak power consumption of the data center was obtained by simple linear regression between power and server utilization.

### C. Simulator Validation

We validated our simulator with 1GigE and IBA based prototype data centers with different number of nodes for each tier. The average latencies of each requests from simulation results were compared with those from real measurements as shown in Figure 4. Here, we selected the number of nodes for each tier in the prototype data center when the latency of requests was minimized. In Figure 4(a) and 4(b), the underlying network architecture was IBA. Figure 4(c) shows the latencies over 1GigE from actual measurements and simulation. In the above results, the latency of each tier from simulation closely matched with the real measurements, which implies our simulator’s underlying architecture captures critical paths in each tier. The average latencies from the simulator match closely with the average deviation of 10%. Note that the above deviation is independent of either the number of nodes or the number of clients used in experiments.

Figure 6 shows the CDF plots of service times of each tier for the simulation and real measurements. According to [28], service time of an actual machine for RUBiS workload follows the Pareto distribution. We notice that the service time of each tier from our simulator closely matched with the real measurements under both the cases of light and heavy traffic. It implies that the modeled behavior for each tier in the simulator is very close to that of actual servers. From both the latency and CDF comparison, we can conclude that our simulator captured accurately the critical behaviors to process requests and showed similar traffic characteristics to real environments.

We validated the estimated power consumption using our simulator with real power measurements. Figure 5 shows the variation of power consumption with the number of clients corresponding to real and estimated power measurements. We used a power measurement device WT210 [32] to measure power usage of nine (the power strip used could only accommodate nine connections at a time) randomly chosen nodes from our prototype data center. These nine nodes were configured as 2 web servers, 6 application servers and 1 database server. The power consumption from our simulator closely matched with that of real measurements with an average deviation of around 3%. This result indicates that our simulator is capable of accurately estimating power consumption across the servers of a multi-tier data center.

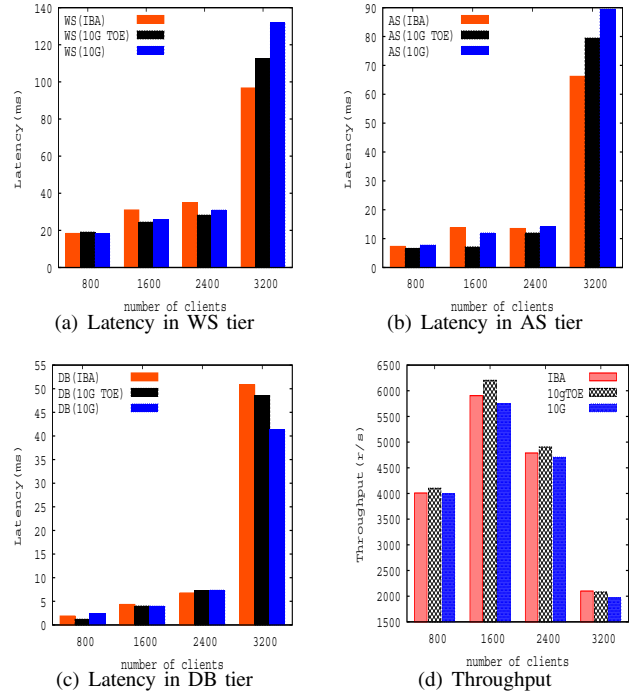

Fig. 7. Comparison between IBA and 10GigE

## V. PERFORMANCE EVALUATION

In this section, we demonstrate three important applications using our simulation platform to show the ability of our simulator for guiding design of data centers. First, comparison between two popular interconnection networks is done in Section V-A. Second, power estimation using simulator is elaborated in Section V-B. Finally, performance prediction according to various system configuration is described in Section V-C.

### A. Comparison between IBA and 10GigE

We conducted comparative performance analysis of 10GigE and IBA for three-tier data centers in terms of latency and throughput. The graphs in Figure 7 depict the average latencies and throughput of requests in terms of the number of clients for three configurations (IBA, 10GigE with TOE and 10GigE without TOE). We used 2 WS nodes, 6 AS nodes, and 3DB nodes for this simulation. Notice that the latency of WS and AS includes the communication overhead between WS and AS and between AS and DB, respectively. We observe that 10GigE, regardless of TOE, has a better or very similar performance over IBA in latency measurement, provided the number of clients is under 3200. However, with the increase in traffic beyond 3200 clients, the latency of IBA comes out to be 14% smaller than 10GigE with TOE and 26.7% lesser than 10GigE without TOE.

Under high traffic, the communication cost which is determined by the mean number of jobs in communication layer is a dominant factor of the response time. Based on the queuing theory, the mean number of jobs in a queue  $J$  is obtained by

$$J = \lambda \times T, \quad (4)$$

where  $\lambda$  is the inter-arrival rate of requests and  $T$  is the mean service time of a single request. Accordingly, given the same inter-arrival rate of requests, the latency under high traffic is mainly affected by the mean service time of a single request, which is the average latency of a single file for the workload in our simulation. Even though the file sizes vary from 1.5KB to 16KB for the RUBiS workload, most of them are clustered around 2.5KB [28]. According to the latency estimation in Table I, the latencies of 10GigE with TOE and without TOE are greater than that of IBA with 2.5KB file size. Hence, IBA has the smallest response time among all the three network interconnections under high communication workload.

We observe that the latency for the DB tier in case of IBA is much higher than that of 10GigE with and without TOE under high traffic (3200 clients as shown in Figure 7(a), 7(b), and 7(c)). This can be explained due to the fact that the throughput of IBA in case of 3200 clients is higher than that of 10GigE, which increases the number of requests generated for the DB tier and thus degrades the response time of the DB tier. This is due to the fact that the blocking operation, which ensures consistency among databases, can cause system overheads in the database servers when the number of concurrent writing operation increases. We notice that the WS part of bar graphs is negligible in some results since the service time of WS which includes communication overheads between AS and WS is less than 10% of the overall latency in most experiments.

### B. Power Measurement

As validated in section IV, our simulator can estimate power consumption across the servers of a data center. The flexibility offered by our simulator allows one to measure the power consumption for any selected number of clients and with any chosen cluster configuration. From Figure 5, we notice that the power consumption across the cluster nodes increases with the increase in the traffic from 800 to 3200 clients for both the prototype data center as well as the simulation platform. Figure 8 shows the estimated power consumption using our simulator across 64 nodes clustered data center connected with IBA, 10GigE with TOE and 10GigE without TOE respectively. Here, S1, S2, and S3 represent three different cluster configurations with varying number of nodes in the WS tier, AS tier, and DB tier respectively for the same total number of nodes. In S1, 8 web servers, 32 application servers, and 24 database servers were used. In S2, 8 web servers, 40 application servers, and 16 database servers were used. S3 consisted of 16 web servers, 32 application servers, and 16 database servers. We expressed power as percentage of peak power. As we observe from Figure 8, power consumed when the number of clients is less, comes out to be more or less same for different cluster configurations in all the three cases (IBA, 10GigE with TOE, 10GigE without TOE). This is because when the traffic is less, the servers are under utilized, and so do not exhibit large power usage. However, with the increase in the traffic, server utilization is enhanced, causing the servers to consume more power. As we observe, the power consumption varies with different cluster configurations even for the same

total number of nodes. This implies the dependency of some specific tier in deciding the power dominance. These results can provide one with the insight into determining the optimal cluster configuration, in terms of reduced power consumption across the cluster (this can be especially important for the designer of a multi-tier data center, where he has to determine the distribution of the number of nodes across each tier based on power efficiency).

### C. Server Configuration

To demonstrate the scalability and flexibility of our simulator, we conducted performance analysis of a three-tier data center with increased number of nodes and with different interconnection networks. Figure 9(a), 9(b), and 9(c) shows the variation of latency with different number of clients for 32, 64, and 128 nodes respectively. The combination of the number of nodes in each tier was selected randomly. We observe that the performance of the data center in terms of latency improves (with the decrease in latency) with an increase in the total number of nodes in the system. This is due to the efficient distribution of system load across multiple nodes of the tiers. However, we observe that this trend is violated for the case with 128 nodes as shown in Figure 9(c). This is due to the large overhead caused by the DB tier locking operation, which causes the total response time to be dominated by the DB portion of latency. These results imply that the performance might not be enhanced in proportion to the number of total nodes. The underlying mechanisms in each server may cause unexpected results if the scalability increases. The above results demonstrate that without real measurement, we can suggest, for given system characteristics, the right choice among possible combinations of server configuration by the simulation.

Next we examine latency variations for a fixed number of total nodes in a data center for different cluster configurations. Figure 10(a), 9(b), and 10(c) depicts the results. We observe that performance of a data center in terms of latency varies based on the different configuration of nodes selected for each tier and also with the type of interconnection used. Also, notice that a better configuration of the system for minimizing the response time can be achieved by selecting more number of AS nodes than WS and DB nodes. This is because AS nodes have CPU intensive jobs and interfaces with two other ends, thus increasing them efficiently distributes the load across the cluster. Thus, our simulator can be used to change various configurations to determine the desired distribution of nodes across the cluster for optimizing performance.

## VI. CONCLUSIONS

In this paper, we first designed and implemented a prototype three-tier IBA and 1GigE connected data center. Since the prototype was limited in terms of the number of cluster nodes, system configurations, and driving workloads, we presented a comprehensive, flexible and scalable simulation platform for the performance and power analysis of multi-tier data centers. The simulator was validated with RUBiS benchmark

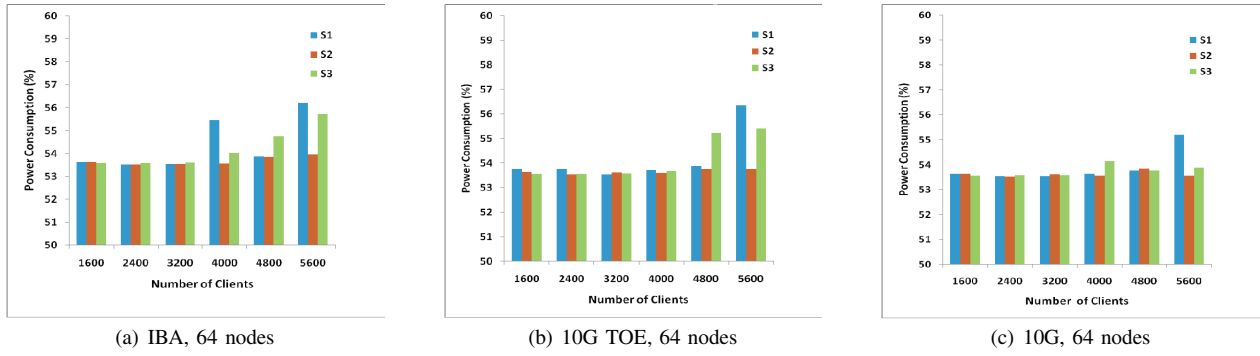

Fig. 8. Estimated Power Consumption

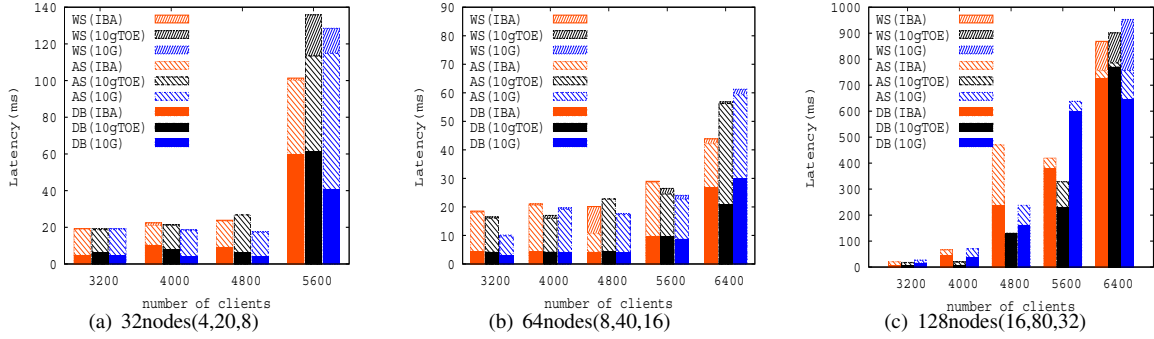

Fig. 9. Latency with varying number of nodes (WS, AS, DB)

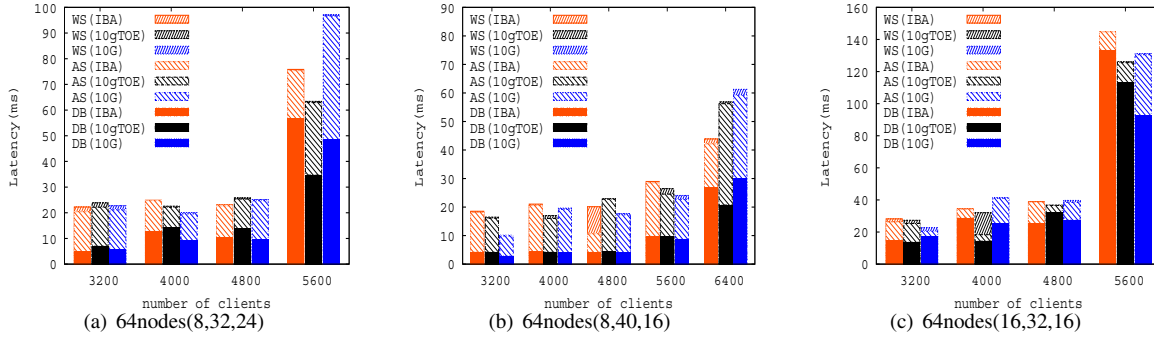

Fig. 10. Latency with varying number of nodes for each tier (WS, AS, DB)

measurements on the above mentioned prototype data center. Using three application studies, we demonstrated how designer of a multi-tier data center might use the proposed simulation framework to conduct performance and power analysis. The first study detailed a comparative analysis of the performance of IBA and 10GigE under varying cluster sizes, network load and with different tier configurations. The results from this experiment indicated that 10GigE with TOE performs better than IBA under light traffic. However, as the load increases, IBA performs better than 10GigE both with and without TOE. Next, we introduced a methodology to perform power measurement in a multi-tier data center using our simulator. Finally, using simulation platform, configuration analysis for performance optimization in terms of reduced network latency was demonstrated.

As a part of our future work, we intend to test our simulation

platform with diverse set of workloads besides RUBiS. Further, we plan to extend our simulation platform for conducting thermal analysis, reliability measurement and servers' provisioning (*i.e.*, determination of the optimal number of servers in each tier based on performance and power) in a multi-tier data center. Also, we are working towards making our simulator a publicly available tool for use in research community in near future.

## REFERENCES

- [1] FinanceTech, "FinanceTechnology Network," 2009, available from <http://www.financtech.com>.
- [2] M. Marwah, R. Sharma, R. Shih, C. Patel, V. Bhatia, M. Mekanapurath, R. Velumani, and S. Velayudhan, "Data analysis, visualization and knowledge discovery in sustainable data centers," in *COMPUTE '09: Proceedings of the 2nd Bangalore Annual Compute Conference*, 2009.



- [3] J. Liu, D. Poff, and B. Abali, "Evaluating high performance communication: a power perspective," in *ICS '09: Proceedings of the 23rd international conference on Supercomputing*.
- [4] W. B. Feng, C. P. Baron, L. Bhuyan, and D. Panda, "Performance characterization of a 10-Gigabit Ethernet TOE," in *High Performance Interconnects, 2005. Proceedings of 13th Symposium on*.
- [5] B. Urgaonkar, G. Pacifici, P. Shenoy, M. Spreitzer, and A. Tantawi, "An analytical model for multi-tier internet services and its applications," in *SIGMETRICS '05*.
- [6] C. Amza, E. Cecchet, A. Chanda, A. L. Cox, S. Elnikety, R. Gil, J. Marguerite, K. Rajamani, and W. Zwaenepoel, "bottleneck characterization of dynamic web site benchmarks," in *Third IBM CAS Conference, 2002*.
- [7] T. F. Abdelzaher, K. G. Shin, and N. Bhatti, "Performance guarantees for web server end-systems: A control-theoretical approach," in *IEEE Transactions on Parallel and Distributed Systems*, vol. 13, no. 1, Jan 2002.
- [8] D. Vilella, P. Pradhan, and D. Rubenstein, "Provisioning servers in the application tier for e-commerce systems," *ACM Trans. Interet Technol.*, vol. 7, no. 1, p. 7, 2007.
- [9] E. Cecchet, J. Marguerite, and W. Zwaenepoel, "Performance and scalability of EJB applications," *SIGPLAN Not.*, vol. 37, no. 11, pp. 246–261, 2002.
- [10] J. Chen, G. Soundararajan, and C. Amza, "Autonomic provisioning of backend databases in dynamic content web servers," *Autonomic Computing, 2006. ICAC '06. IEEE International Conference on*.
- [11] C. Stewart and K. Shen, "performance modeling and system management for multi-component online service," in *NSDI '05: 2nd Symposium on Networked Systems Design & Implementation, 2005*.
- [12] P. Balaji, S. Narravula, K. Vaidyanathan, S. Krishnamoorthy, J. Wu, and D. K. Panda, "Sockets Direct Protocol over InfiniBand in clusters: is it beneficial?" in *ISPASS '04: Proceedings of the 2004 IEEE International Symposium on Performance Analysis of Systems and Software, 2004*.
- [13] Sun Microsystems, Inc., "J2EE: Java 2 Platform Enterprise Edition," 2003, available from <http://java.sun.com/j2ee/>.
- [14] S. Gurumurthi, A. Sivasubramaniam, M. J. Irwin, N. Vijaykrishnan, M. Kandemir, T. Li, and L. K. John, "Using complete machine simulation for software power estimation: The softwatt approach," in *HPCA '02: Proceedings of the 8th International Symposium on High-Performance Computer Architecture, 2002*.
- [15] W. Wu, L. Jin, J. Yang, P. Liu, and S. X.-D. Tan, "Efficient power modeling and software thermal sensing for runtime temperature monitoring," *ACM Trans. Des. Autom. Electron. Syst.*, vol. 12, no. 3, pp. 1–29, 2007.
- [16] C.-H. Hsu and W.-C. Feng, "A power-aware run-time system for high-performance computing," in *SC '05: Proceedings of the 2005 ACM/IEEE conference on Supercomputing, 2005*.
- [17] V. W. Freeh, F. Pan, N. Kappiah, D. K. Lowenthal, and R. Springer, "Exploring the energy-time tradeoff in mpi programs on a power-scalable cluster," in *IPDPS '05: Proceedings of the 19th IEEE International Parallel and Distributed Processing Symposium, 2005*.
- [18] C. Rusu, A. Ferreira, C. Scordino, and A. Watson, "Energy-efficient real-time heterogeneous server clusters," in *RTAS '06: Proceedings of the 12th IEEE Real-Time and Embedded Technology and Applications Symposium, 2006*.
- [19] M. Elnozahy, M. Kistler, and R. Rajamony, "Energy conservation policies for web servers," in *USITS'03: Proceedings of the 4th conference on USENIX Symposium on Internet Technologies and Systems*.
- [20] R. Bianchini and R. Rajamony, "Power and energy management for server systems," *Computer*, vol. 37, no. 11, pp. 68–76, Nov. 2004.
- [21] Mesquite Software, "CSIM," <http://www.mesquite.com>.
- [22] InfiniBand Trade Association, "InfiniBand Architecture Specification, Volume 1 & 2, Release 1.2," October 2004, <http://www.infinibandta.org>.
- [23] The Apache Software Foundation, "The Apache HTTP Server Project," 2003, <http://httpd.apache.org>.
- [24] ObjectWeb Consortuim, "JOnAS," 2006, <http://jonas.objectweb.org>.
- [25] MySQL, "MySQL," 2006, available from <http://www.mysql.com>.
- [26] ObjectWeb Consortuim, "C-JDBC," 2006, <http://c-jdbc.objectweb.org>.
- [27] D. F. Garcia and J. Garcia, "Tpc-w e-commerce benchmark evaluation," *Computer*, vol. 36, no. 2, pp. 42–48, 2003.
- [28] D. Ersoz, M. S. Yousif, and C. R. Das, "Characterizing network traffic in a cluster-based, multi-tier data center," in *ICDCS '07: Proceedings of the 27th International Conference on Distributed Computing Systems*.
- [29] G. E. Alliance, <http://www.10gea.org>.
- [30] B. Urgaonkar, P. Shenoy, A. Chandra, and P. Goyal, "Dynamic provisioning of multi-tier internet applications," in *Autonomic Computing, 2005. ICAC 2005. Proceedings. Second International Conference on*.
- [31] Z. Wang, C. McCarthy, X. Zhu, P. Ranganathan, and V. Talwar, "Feedback control algorithms for power management of servers," in *3rd Workshop on Feedback Control Implementation and Design in Computing Systems and Networks (FeBID'08)*, Jun 2008.
- [32] Yokogawa Electric Corporation, "WT210 Digital Power Meter User's Manual," May 1998.